

Low Voltage Surface Mount TMOS™ Power MOSFET Selector Guide

ON Semiconductor

The logo consists of a green circle with the letters "ON" in white, bold, sans-serif font.The background of the page is a close-up, high-angle photograph of a printed circuit board (PCB) populated with numerous surface-mount components. The image is overlaid with a semi-transparent teal color. The components are densely packed, and the perspective is looking down at the board, showing the intricate wiring and solder connections.

Featuring MiniMOS™ (SO-8), EZFET™, Micro8™, SOT-223,
TSOP-6, SOT-23, SC-70/SOT-323, DPAK and D²PAK



TMOS Power MOSFETs

TMOS Power MOSFETs Numbering System

Wherever possible, ON Semiconductors has used the following numbering systems for TMOS power MOSFET products.

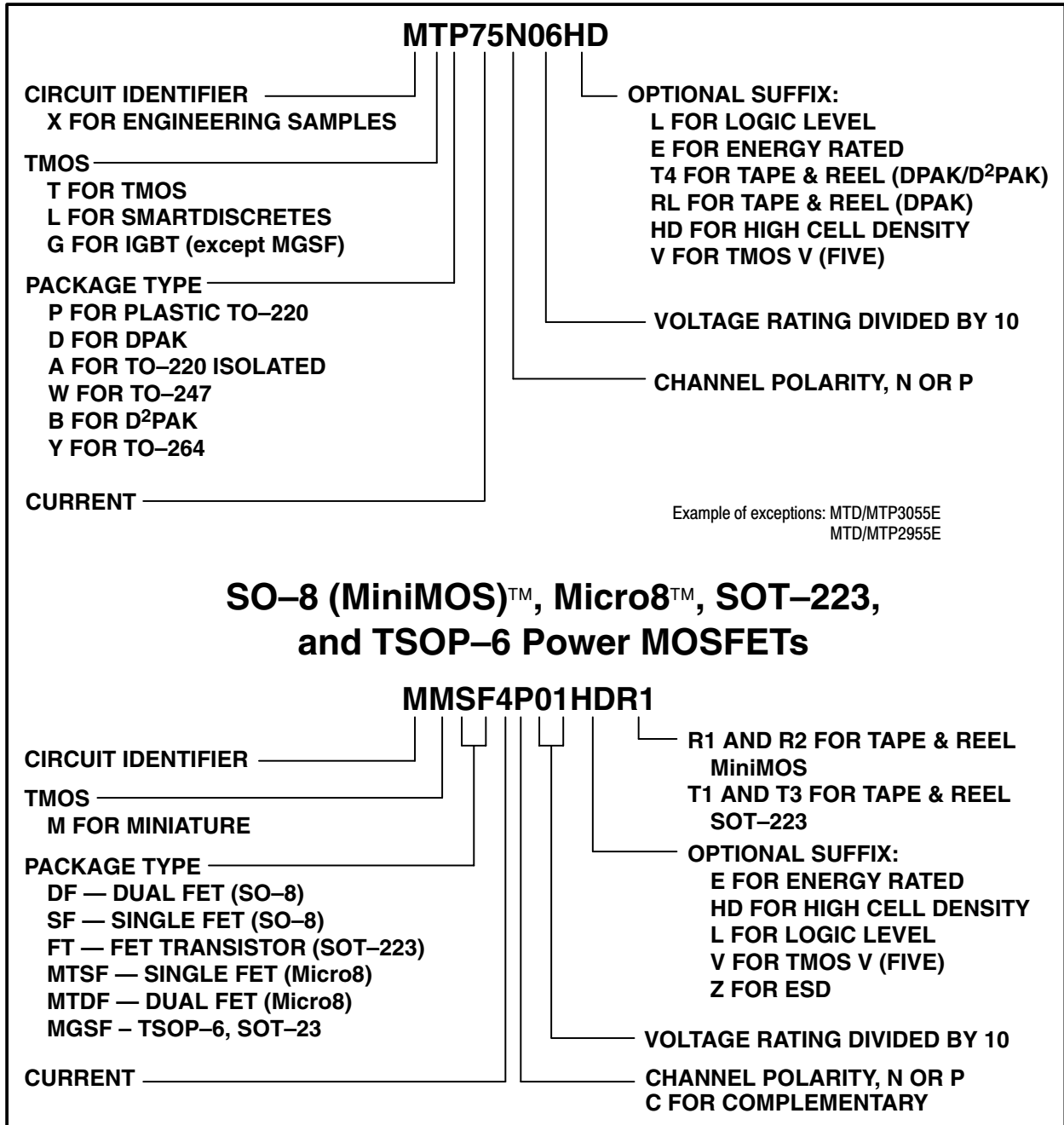

Part Numbering System

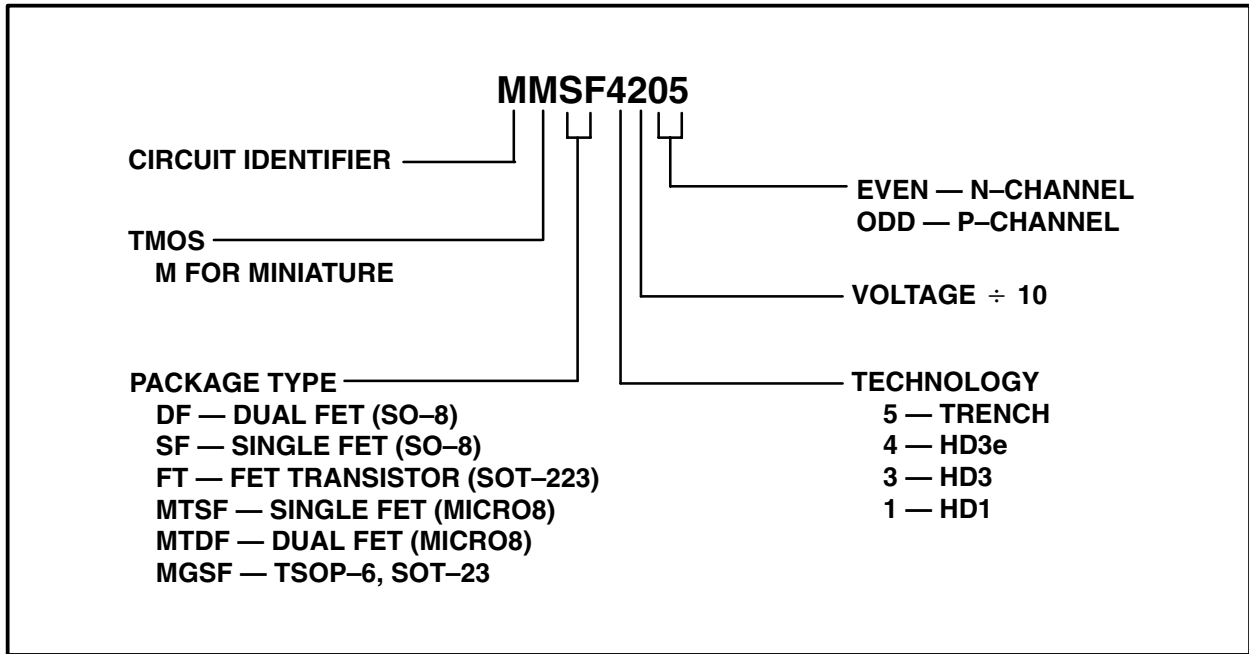

CASE 419-02
SC-70



CASE 318-09
SOT-23



CASE 318G-02
TSOP-6



CASE 846A-02
Micro8



CASE 318E-04
SOT-223



CASE 751-06
SO-8



CASE 369A-13
TO-252, DPAK



CASE 418B-03
TO-264, D²PAK

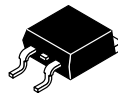

Packages Not to Scale

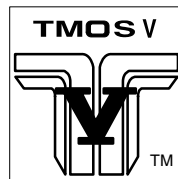

Table 1. SO-8 (MiniMOS™) — Case 751-06

V _{(BR)DSS} (Volts) Min	Max R _{DS(on)} @ V _{GS}				I _D (cont) Amps	Device ⁽³⁾	P _D ^(1,2) (Watts) Max	Configuration ⁽⁵⁾
	10 V (Ω)	4.5 V (Ω)	2.7 V (Ω)	2.5 V (Ω)				
60	—	0.130 ⁽⁴⁾	—	—	3.3	MMDF3N06VL	2.0	Dual N-Channel
	0.100	0.200	—	—	3.3	MMDF3N06HD		
50	0.300	0.500	—	—	2.0	MMDF1N05E	2.0	Dual N-Channel
40	0.080	0.100	—	—	3.4	MMDF3N04HD		
30	0.030	0.039	—	—	7.0	MMSF1308	2.5	Single N-Channel
	0.015	0.019	—	—	10.0	MMSF1310		
	0.0125	0.020	—	—	11.5	MMSF3300		
	0.040	0.050	—	—	6.5	MMSF5N03HD		
	0.028	0.040	—	—	8.2	MMSF7N03HD		
	0.100	0.110	—	—	4.6	MMSF3P03HD	2.0	Single P-Channel
	0.035	0.050	—	—	7.0	MMSF7P03HD		
	0.070	0.075	—	—	4.1	MMDF3N03HD		
	0.035	0.050	—	—	6.0	MMDF6N03HD		
	0.200	0.300	—	—	3.0	MMDF2P03HD		
0.085	0.160	—	—	3.5	MMDF4P03HD	2.0	Dual P-Channel	
0.070/0.200	0.075/0.300	—	—	4.1	MMDF2C03HD			
0.050/0.085	0.080/0.160	—	—	5.5/4.4	MMDF4C03HD	2.5	Complementary	
25	0.035	0.050	—	—	5.0	MMDFS6N303	2.0	MOSFET/Schottky
	0.100	0.160	—	—	3.5	MMDFS3P303		
25	0.100/0.210	0.160/0.375	—	—	3.0/2.0	MMDF1300	1.8	Complementary
	0.250	0.400	—	—	2.5	MMDF2P02E	2.0	Dual P-Channel
	0.100/0.250	0.200/0.400	—	—	3.6	MMDF2C02E		Complementary
	0.100	0.200	—	—	3.6	MMDF2N02E		Dual N-Channel
20	—	0.045	0.055	—	4.0	MMSF4N01HD	2.5	Single N-Channel
	0.025	0.040	—	—	8.2	MMSF5N02HD		
	0.250	0.400	—	—	2.5	MMSF2P02E		
	0.075	0.095	—	—	5.6	MMSF3P02HD		
	—	0.030	—	0.045	8.7	MMSF5P02HD		
	—	0.014	—	0.020	10.0	MMSF4205	2.0	Single P-Channel
	—	0.045	0.055	—	5.2	MMDF4N01HD		
	—	0.035	—	0.049	6.5	MMDF6N02HD		
	0.160	0.180	—	—	3.3	MMDF2P02HD		
	—	0.033	—	0.050	7.8	MMDF4207		
0.090	0.100	—	—	3.8	MMDF3N02HD	2.0	Dual N-Channel	
0.090/0.160	0.100/0.180	—	—	3.8	MMDF2C02HD		Complementary	
0.160	0.180	—	—	2.0	MMDFS2P102		MOSFET/Schottky	
12	—	0.080	0.090	—	5.1	MMSF4P01HD	2.5	Single P-Channel
	—	0.180	0.220	—	3.4	MMDF2P01HD	2.0	Dual P-Channel
	—	0.045/0.180	—	—	5.2	MMDF2C01HD		Complementary

(1) T_C = 25°C
 (2) See Data Sheet for Applicable Mounting Configuration.
 (3) Available in Tape and Reel only. R2 suffix = 2500 per reel.
 (4) V_{GS} = 5 V
 (5) Data for all Complementary Devices listed as Nch/Pch.
 Devices listed in **bold, italic** are ON Semiconductor preferred devices.

Table 2. EZFET™ — SO-8 Power MOSFETs with Zener Gate Protection — Case 751-06

V _{(BR)DSS} (Volts) Min	Max R _{DS(on)} @ V _{GS}				I _D (cont) Amps	Device ⁽³⁾	P _D ^(1,2) (Watts) Max	Configuration
	10 V (Ω)	4.5 V (Ω)	2.7 V (Ω)	2.5 V (Ω)				
50	0.3	—	—	—	2.0	MMDF2N05Z	2.0	Dual N-Channel
30	0.03	0.04	—	—	7.5	MMSF7N03Z	2.5	Single N-Channel
	0.013	0.018	—	—	10	MMSF10N03Z	1.6	
20	—	0.015	0.019	—	10	MMSF10N02Z	2.5	Dual N-Channel
	—	0.04	0.05	—	5.0	MMDF5N02Z	2.0	
	—	0.027	—	0.035	7.0	MMDF7N02Z		

(1) T_C = 25°C
 (2) See Data Sheet for Applicable Mounting Configuration
 (3) Available in Tape and Reel only. R2 suffix = 2500 per reel.

Table 3. Micro8™ — Case 846A-02

V _{(BR)DSS} (Volts) Min	Max R _{DS(on)} @ V _{GS}				I _D (cont) Amps	Device ⁽³⁾	P _D ^(1,2) (Watts) Max	Configuration
	10 V (Ω)	4.5 V (Ω)	2.7 V (Ω)	2.5 V (Ω)				
60	0.22	0.26	—	—	1.5	MTDF2N06HD	1.25	Dual N-Channel
30	0.04	0.06	—	—	5.7	MTSF3N03HD	1.79	Single N-Channel
	0.09	0.15	—	—	4.1	MTSF2P03HD		Single P-Channel
	0.12	0.16	—	—	1.9	MTDF1N03HD	1.25	Dual N-Channel
20	—	0.04	0.05	—	6.1	MTSF3N02HD	1.79	Single N-Channel
	—	0.16	0.19	—	1.8	MTSF1P02HD	1.8	Single P-Channel
	—	0.09	0.12	—	2.4	MTSF2P02HD		
	—	0.12	0.16	—	1.9	MTDF1N02HD	1.25	Dual N-Channel
	—	0.175	0.28	—	2.3	MTDF1P02HD		Dual P-Channel
	—	0.12/0.175	0.16/0.28	—	2.8	MTDF1C02HD		Complementary

(1) T_C = 25°C

(2) See Data Sheet for Applicable Mounting Configuration

(3) Available in Tape and Reel only. R2 suffix = 2500 per reel.

Table 4. SOT-223 — Case 318E-04

V _{(BR)DSS} (Volts) Min	Max R _{DS(on)} @ V _{GS}				I _D (cont) Amps	Device ⁽³⁾	P _D ^(1,2) (Watts) Max
	10 V (Ω)	5.0 V (Ω)	2.7 V (Ω)	2.5 V (Ω)			

SOT-223 — N-Channel

200	14	—	—	—	0.25	MMFT107	0.8
	1.5	—	—	—	0.3	MMFT1N20	
100	0.25	—	—	—	1.0	MMFT1N10E	
90	6.0	—	—	10	0.7	MMFT2406	1.5
60	0.13	—	—	—	1.7	MMFT3055V	2.0
	—	0.14	—	—	1.5	MMFT3055VL	
	1.7	—	—	—	0.3	MMFT960	0.8
20	—	0.15	—	—	1.6	MMFT2N02EL	

SOT-223 — P-Channel

60	0.3	—	—	—	1.2	MMFT2955E	0.8
30	0.1	—	—	—	5.2	MMFT5P03HD	3.73

(1) T_C = 25°C

(2) See Data Sheet for Applicable Mounting Configuration

(3) Available in Tape and Reel only. T1 suffix = 1000 per reel, T3 suffix = 4000 per reel.

Table 5. TSOP-6 — Case 318G-02

V _{(BR)DSS} (Volts) Min	Max R _{DS(on)} @ V _{GS}				I _D (cont) Amps	Device	P _D ^(1,2) (Watts) Max
	10 V (Ω)	4.5 V (Ω)	2.7 V (Ω)	2.5 V (Ω)			

TSOP-6 — N-Channel

30	0.065	0.095	—	—	1.75	MGSF3454XT1	0.95
	0.065	0.095	—	—	4.2	MGSF3454VT1	2.0
20	—	0.07	—	0.095	1.7	MGSF3442XT1	0.4
	—	0.07	—	0.095	4.0	MGSF3442VT1	2.0

TSOP-6 — P-Channel

30	0.1	0.19	—	—	1.45	MGSF3455XT1	0.4
	0.1	0.19	—	—	3.5	MGSF3455VT1	2.0
20	—	0.1	—	0.135	1.5	MGSF3441XT1	0.95
	—	0.9	—	0.135	3.3	MGSF3441VT1	2.0
	—	0.175	0.28	—	1.3	MGSF2P02HD	0.4
12	—	—	—	0.098	3.3	MGSF3433VT1	2.0

(1) T_C = 25°C

(2) See Data Sheet for Applicable Mounting Configuration

Table 6. SOT-23 — Case 318-08

$V_{(BR)DSS}$ (Volts) Min	Max $R_{DS(on)}$ @ V_{GS}			I_D (cont) Amps	Device	$P_D^{(1,2)}$ (Watts) Max
	10 V (Ω)	4.5 V (Ω)	2.5 V (Ω)			
SOT-23 — N-Channel						
60	5.0	—	—	0.50	<i>MMBF170LT1</i>	0.225
	7.5	—	—	0.115	<i>2N7002LT1</i>	
50	—	3.5 @ 5 V	7 @ 2.75	0.20	<i>BSS138LT1</i>	
30	—	—	—	0.1	<i>MMBF1374T1</i>	0.100
	0.1	0.145	—	0.75	<i>MGSF1N03LT1</i>	
20	0.09	0.13	—	0.75	<i>MGSF1N02LT1</i>	0.225
	1.0	1.4	—	0.3	<i>MMBF0201NLT1</i>	
	—	0.085	0.115	0.75	<i>MGSF1N02ELT1</i>	
SOT-23 — P-Channel						
50	—	10 @ 5 V	—	0.1	<i>BSS84LT1</i>	0.225
20	—	0.26	0.5	0.75	<i>MGSF1P02ELT1</i>	0.4
	0.35	0.5	—	—	<i>MGSF1P02LT1</i>	
	1.4	3.5	—	0.3	<i>MMBF0202PLT1</i>	0.225

(1) $T_C = 25^\circ\text{C}$
 (2) See Data Sheet for Applicable Mounting Configuration

Table 7. SC-70 / SOT-323 — Case 419-02

$V_{(BR)DSS}$ (Volts) Min	Max $R_{DS(on)}$ @ V_{GS}			I_D (cont) Amps	Device	$P_D^{(1,2)}$ (Watts) Max	V_{GS} (Volts) Min
	10 V (Ω)	4.5 V (Ω)	2.7 V (Ω)				
SC-70/SOT-323 — N-Channel							
30	—	5.0	—	0.10	<i>MMBF1374T1</i>	0.10	1.0
20	1.0	1.4	—	0.30	<i>MMBF2201NT1</i>	0.15	
SC-70/SOT-323 — P-Channel							
20	2.2	3.5	—	0.30	<i>MMBF2202PT1</i>	0.15	1.0

(1) $T_C = 25^\circ\text{C}$
 (2) See Data Sheet for Applicable Mounting Configuration

Table 8. DPAK — Case 369A-13 (TO-252)

$V_{(BR)DSS}$ (Volts) Min	Max $R_{DS(on)}$ @ V_{GS}			I_D (cont) Amps	Device ⁽³⁾	$P_D^{(1,2)}$ (Watts) Max
	10 V (Ω)	5.0 V (Ω)	2.7 V (Ω)			
DPAK — N-Channel						
800	12	—	—	1.0	<i>MTD1N80E</i>	48
600	2.3	—	—	4.0	<i>NTD4N60</i>	96
500	5.0	—	—	1.0	<i>MTD1N50E</i>	40
	3.6	—	—	2.0	<i>MTD2N50E</i>	
	1.8	—	—	5.0	<i>NTD5N50</i>	
400	3.5	—	—	2.0	<i>MTD2N40E</i>	40
	1.1	—	—	6.0	<i>NTD6N40</i>	96
250	1.40	—	—	3.0	<i>MTD3N25E</i>	40
200	1.20	—	—	4.0	<i>MTD4N20E</i>	
100	0.25	—	—	9.0	<i>MTD9N10E</i>	
60	—	0.18	—	12	<i>MTD3055VL</i>	48
	—	0.085	—	15	<i>MTD15N06VL</i>	60
	0.12	—	—	15	<i>MTD15N06V</i>	55
	0.15	—	—	12	<i>MTD3055V</i>	48
	0.045	—	—	20	<i>MTD20N06HD</i>	40
	—	0.045	—	20	<i>MTD20N06HDL</i>	
30	0.010	—	—	30	<i>MTD3302</i>	96
	—	0.035	—	20	<i>MTD20N03HDL</i>	74
	0.022	—	—	20	<i>MTD1302</i>	

(1) $T_C = 25^\circ\text{C}$
 (2) See Data Sheet for Applicable Mounting Configuration
 (3) Available in Tape and Reel. T4 suffix = 2500 per reel.

Table 8. DPAK — Case 369A–13 (TO–252) (continued)

$V_{(BR)DSS}$ (Volts) Min	Max $R_{DS(on)}$ @ V_{GS}			I_D (cont) Amps	Device ⁽³⁾	$P_D^{(1,2)}$ (Watts) Max
	10 V (Ω)	5.0 V (Ω)	2.7 V (Ω)			
DPAK — P-Channel						
500	15.0	—	—	1.0	<i>MTD1P50E</i>	50
400	8.0	—	—	1.0	<i>MTD1P40E</i>	65
60	0.45	—	—	5.0	<i>MTD5P06V</i>	40
	0.20	—	—	12	<i>MTD2955V</i>	60
30	—	0.175	—	15	<i>MTD20P06HDL</i>	72
	—	0.099	—	19	<i>MTD20P03HDL</i>	75

(1) $T_C = 25^\circ\text{C}$

(2) See Data Sheet for Applicable Mounting Configuration

(3) Available in Tape and Reel. T4 suffix = 2500 per reel.

Table 9. D²PAK — Case 418B–03 (TO–264)

$V_{(BR)DSS}$ (Volts) Min	Max $R_{DS(on)}$ @ V_{GS}			I_D (cont) Amps	Device ⁽³⁾	$P_D^{(1,2)}$ (Watts) Max
	10 V (Ω)	5.0 V (Ω)	2.7 V (Ω)			
D²PAK — N-Channel						
1200	5.0	—	—	3.0	<i>MTB3N120E</i>	125
1000	9.0	—	—	1.0	<i>MTB1N100E</i>	75
	4.0	—	—	3.0	<i>MTB3N100E</i>	125
800	3.0	—	—	4.0	<i>MTB4N80E</i>	125
600	1.2	—	—	6.0	<i>MTB6N60E</i>	125
	2.2	—	—	3.0	<i>MTB3N60E</i>	75
	1.1	—	—	6.0	<i>NTB6N60</i>	142
	0.75	—	—	10	<i>NTB10N60</i>	201
500	0.8	—	—	8.0	<i>MTB8N50E</i>	125
	0.8	—	—	8.0	<i>NTB8N50</i>	142
	0.55	—	—	12	<i>NTB12N50</i>	201
400	0.55	—	—	10	<i>MTB10N40E</i>	125
	0.5	—	—	10	<i>NTB10N40</i>	142
	0.33	—	—	15	<i>NTB15N40</i>	201
250	0.45	—	—	9.0	<i>MTB9N25E</i>	80
200	0.16	—	—	20	<i>MTB20N20E</i>	125
150	0.07	—	—	29	<i>MTB29N15E</i>	125
100	0.060	—	—	33	<i>MTB33N10E</i>	125
	0.04	—	—	40	<i>MTB40N10E</i>	169
60	0.12	—	—	15	<i>MTB15N06V</i>	55
	—	0.032	—	42	<i>MTB50N06VL</i>	125
	0.022	—	—	52	<i>MTB52N06V</i>	165
	—	0.05	—	30	<i>MTB30N06VL</i>	90
	0.04	—	—	32	<i>MTB36N06V</i>	90
	0.028	—	—	42	<i>MTB50N06V</i>	125
	—	0.025	—	52	<i>MTB52N06VL</i>	188
	0.016	—	—	55	<i>MTB55N06Z</i>	136
	0.014	—	—	60	<i>MTB60N06HD</i>	125
	0.01	—	—	75	<i>MTB75N06HD</i>	125
50	0.0095	—	—	75	<i>MTB75N05HD</i>	125
	—	0.014	—	60	<i>MTB60N05HDL</i>	150
30	0.0065	—	—	75	<i>MTB1306</i>	125
25	—	0.009	—	75	<i>MTB75N03HDL</i>	125

Table 9. D²PAK — Case 418B-03 (TO-264) (continued)

V _{(BR)DSS} (Volts) Min	Max R _{DS(on)} @ V _{GS}			I _D (cont) Amps	Device ⁽³⁾	P _D ^(1,2) (Watts) Max
	10 V (Ω)	5.0 V (Ω)	2.7 V (Ω)			
D²PAK — P-Channel						
60	0.12	—	—	23	<i>MTB23P06V</i>	90
400	0.08	—	—	30	<i>MTB30P06V</i>	125
30	—	0.025	—	50	<i>MTB50P03HDL</i>	

(1) T_C = 25°C
 (2) See Data Sheet for Applicable Mounting Configuration
 (3) Available in Tape and Reel. T4 suffix = 800 per reel.

ON SEMICONDUCTOR MAJOR WORLDWIDE SALES OFFICES

UNITED STATES

- ALABAMA**
Huntsville (256)464-6800
- CALIFORNIA**
Irvine (949)753-7360
San Jose (408)749-0510
- COLORADO**
Littleton (303)256-5884
- FLORIDA**
Tampa (813)286-6181
- GEORGIA**
Atlanta (770)338-3810
- ILLINOIS**
Chicago (847)413-2500
- MASSACHUSETTS**
Boston (781)932-9700
- MICHIGAN**
Detroit (248)347-6800
- MINNESOTA**
Plymouth (612)249-2360
- NORTH CAROLINA**
Raleigh (919)870-4355
- PENNSYLVANIA**
Philadelphia/Horsham (215)957-4100
- TEXAS**
Dallas (972)516-5100

CANADA

- ONTARIO**
Ottawa (613)226-3491
- QUEBEC**
Montreal (514)333-3300

INTERNATIONAL

- BRAZIL**
Sao Paulo 55(011)3030-5244
- CHINA**
Beijing 86-10-65642288
Guangzhou 86-20-87537888
Shanghai 86-21-63747668
- FRANCE**
Paris 33134 635900
- GERMANY**
Munich 49 89 92103-0
- HONG KONG**
Hong Kong 852-2-610-6888
- INDIA**
Bangalore 91-80-5598615
- ISRAEL**
Tel Aviv 972-9-9522333
- ITALY**
Milan 39(02)82201
- JAPAN**
Tokyo 81-3-5487-8345

INTERNATIONAL (continued)

- KOREA**
Seoul 82-2-3440-7200
- MALAYSIA**
Penang 60(4)228-2514
- MEXICO**
Guadalajara 52(36)78-0750
- PHILIPPINES**
Manila (63)2 807-8455
- PUERTO RICO**
San Juan (787)641-4100
- SINGAPORE**
Singapore (65)4818188
- SPAIN**
Madrid 34(1)457-8204
or 34(1)457-8254
- SWEDEN**
Stockholm 46(8)734-8800
- TAIWAN**
Taipei 886(2)27058000
- THAILAND**
Bangkok 66(2)254-4910
- UNITED KINGDOM**
Aylesbury 44 1 (296)395252

TMOS, the TMOS logo, MiniMOS, EZFET, TMOS Vand the TMOS V logo are trademarks of Semiconductor Components Industries, LLC.
 HDTMOS and the HDTMOS logo are registered trademarks of Semiconductor Components Industries, LLC.
 Micro8 is a trademark of International Rectifier.

ON SEMICONDUCTOR STANDARD DOCUMENT TYPE DEFINITIONS**DATA SHEET CLASSIFICATIONS**

A Data Sheet is the fundamental publication for each individual product/device, or series of products/devices, containing detailed parametric information and any other key information needed in using, designing-in or purchasing of the product(s)/device(s) it describes. Below are the three classifications of Data Sheet: Product Preview; Advance Information; and Fully Released Technical Data

PRODUCT PREVIEW

A Product Preview is a summary document for a product/device under consideration or in the early stages of development. The Product Preview exists only until an “Advance Information” document is published that replaces it. The Product Preview is often used as the first section or chapter in a corresponding reference manual. The Product Preview displays the following disclaimer at the bottom of the first page: “This document contains information on a product under development. ON Semiconductor reserves the right to change or discontinue this product without notice.”

ADVANCE INFORMATION

The Advance Information document is for a device that is NOT fully qualified, but is in the final stages of the release process, and for which production is eminent. While the commitment has been made to produce the device, final characterization and qualification may not be complete. The Advance Information document is replaced with the “Fully Released Technical Data” document once the device/part becomes fully qualified. The Advance Information document displays the following disclaimer at the bottom of the first page: “This document contains information on a new product. Specifications and information herein are subject to change without notice.”

FULLY RELEASED TECHNICAL DATA

The Fully Released Technical Data document is for a product/device that is in full production (i.e., fully released). It replaces the Advance Information document and represents a part that is fully qualified. The Fully Released Technical Data document is virtually the same document as the Product Preview and the Advance Information document with the exception that it provides information that is unavailable for a product in the early phases of development, such as complete parametric characterization data. The Fully Released Technical Data document is also a more comprehensive document than either of its earlier incarnations. This document displays no disclaimer, and while it may be informally referred to as a “data sheet,” it is not labeled as such.

DATA BOOK

A Data Book is a publication that contains primarily a collection of Data Sheets, general family and/or parametric information, Application Notes and any other information needed as reference or support material for the Data Sheets. It may also contain cross reference or selector guide information, detailed quality and reliability information, packaging and case outline information, etc.

APPLICATION NOTE

An Application Note is a document that contains real-world application information about how a specific ON Semiconductor device/product is used, or information that is pertinent to its use. It is designed to address a particular technical issue. Parts and/or software must already exist and be available.

SELECTOR GUIDE

A Selector Guide is a document published, generally at set intervals, that contains key line-item, device-specific information for particular products or families. The Selector Guide is designed to be a quick reference tool that will assist a customer in determining the availability of a particular device, along with its key parameters and available packaging options. In essence, it allows a customer to quickly “select” a device. For detailed design and parametric information, the customer would then refer to the device’s Data Sheet. The *Master Components Selector Guide* (SG388/D) is a listing of **ALL** currently available ON Semiconductor devices.

REFERENCE MANUAL

A Reference Manual is a publication that contains a comprehensive system or device-specific descriptions of the structure and function (operation) of a particular part/system; used overwhelmingly to describe the functionality or application of a device, series of devices or device category. Procedural information in a Reference Manual is limited to less than 40 percent (usually much less).

HANDBOOK

A Handbook is a publication that contains a collection of information on almost any give subject which does not fall into the Reference Manual definition. The subject matter can consist of information ranging from a device specific design information, to system design, to quality and reliability information.

ADDENDUM

A documentation Addendum is a supplemental publication that contains missing information or replaces preliminary information in the primary publication it supports. Individual addendum items are published cumulatively. The Addendum is destroyed upon the next revision of the primary document.

ON Semiconductor and  are trademarks of Semiconductor Components Industries, LLC (SCILLC). SCILLC reserves the right to make changes without further notice to any products herein. SCILLC makes no warranty, representation or guarantee regarding the suitability of its products for any particular purpose, nor does SCILLC assume any liability arising out of the application or use of any product or circuit, and specifically disclaims any and all liability, including without limitation special, consequential or incidental damages. "Typical" parameters which may be provided in SCILLC data sheets and/or specifications can and do vary in different applications and actual performance may vary over time. All operating parameters, including "Typicals" must be validated for each customer application by customer's technical experts. SCILLC does not convey any license under its patent rights nor the rights of others. SCILLC products are not designed, intended, or authorized for use as components in systems intended for surgical implant into the body, or other applications intended to support or sustain life, or for any other application in which the failure of the SCILLC product could create a situation where personal injury or death may occur. Should Buyer purchase or use SCILLC products for any such unintended or unauthorized application, Buyer shall indemnify and hold SCILLC and its officers, employees, subsidiaries, affiliates, and distributors harmless against all claims, costs, damages, and expenses, and reasonable attorney fees arising out of, directly or indirectly, any claim of personal injury or death associated with such unintended or unauthorized use, even if such claim alleges that SCILLC was negligent regarding the design or manufacture of the part. SCILLC is an Equal Opportunity/Affirmative Action Employer.

PUBLICATION ORDERING INFORMATION

NORTH AMERICA Literature Fulfillment:

Literature Distribution Center for ON Semiconductor
P.O. Box 5163, Denver, Colorado 80217 USA
Phone: 303-675-2175 or 800-344-3860 Toll Free USA/Canada
Fax: 303-675-2176 or 800-344-3867 Toll Free USA/Canada
Email: ONlit@hibbertco.com
Fax Response Line: 303-675-2167 or 800-344-3810 Toll Free USA/Canada

N. American Technical Support: 800-282-9855 Toll Free USA/Canada

EUROPE: LDC for ON Semiconductor - European Support

German Phone: (+1) 303-308-7140 (Mon-Fri 2:30pm to 7:00pm CET)
Email: ONlit-german@hibbertco.com
French Phone: (+1) 303-308-7141 (Mon-Fri 2:00pm to 7:00pm CET)
Email: ONlit-french@hibbertco.com
English Phone: (+1) 303-308-7142 (Mon-Fri 12:00pm to 5:00pm GMT)
Email: ONlit@hibbertco.com

EUROPEAN TOLL-FREE ACCESS*: 00-800-4422-3781

*Available from Germany, France, Italy, England, Ireland

CENTRAL/SOUTH AMERICA:

Spanish Phone: 303-308-7143 (Mon-Fri 8:00am to 5:00pm MST)
Email: ONlit-spanish@hibbertco.com

ASIA/PACIFIC: LDC for ON Semiconductor - Asia Support

Phone: 303-675-2121 (T-F 9:00am to 1:00pm Hong Kong Time)
Toll Free from Hong Kong & Singapore:
001-800-4422-3781
Email: ONlit-asia@hibbertco.com

JAPAN: ON Semiconductor, Japan Customer Focus Center
4-32-1 Nishi-Gotanda, Shinagawa-ku, Tokyo, Japan 141-0031

Phone: 81-3-5740-2745
Email: r14525@onsemi.com

ON Semiconductor Website: <http://onsemi.com>

For additional information, please contact your local Sales Representative